

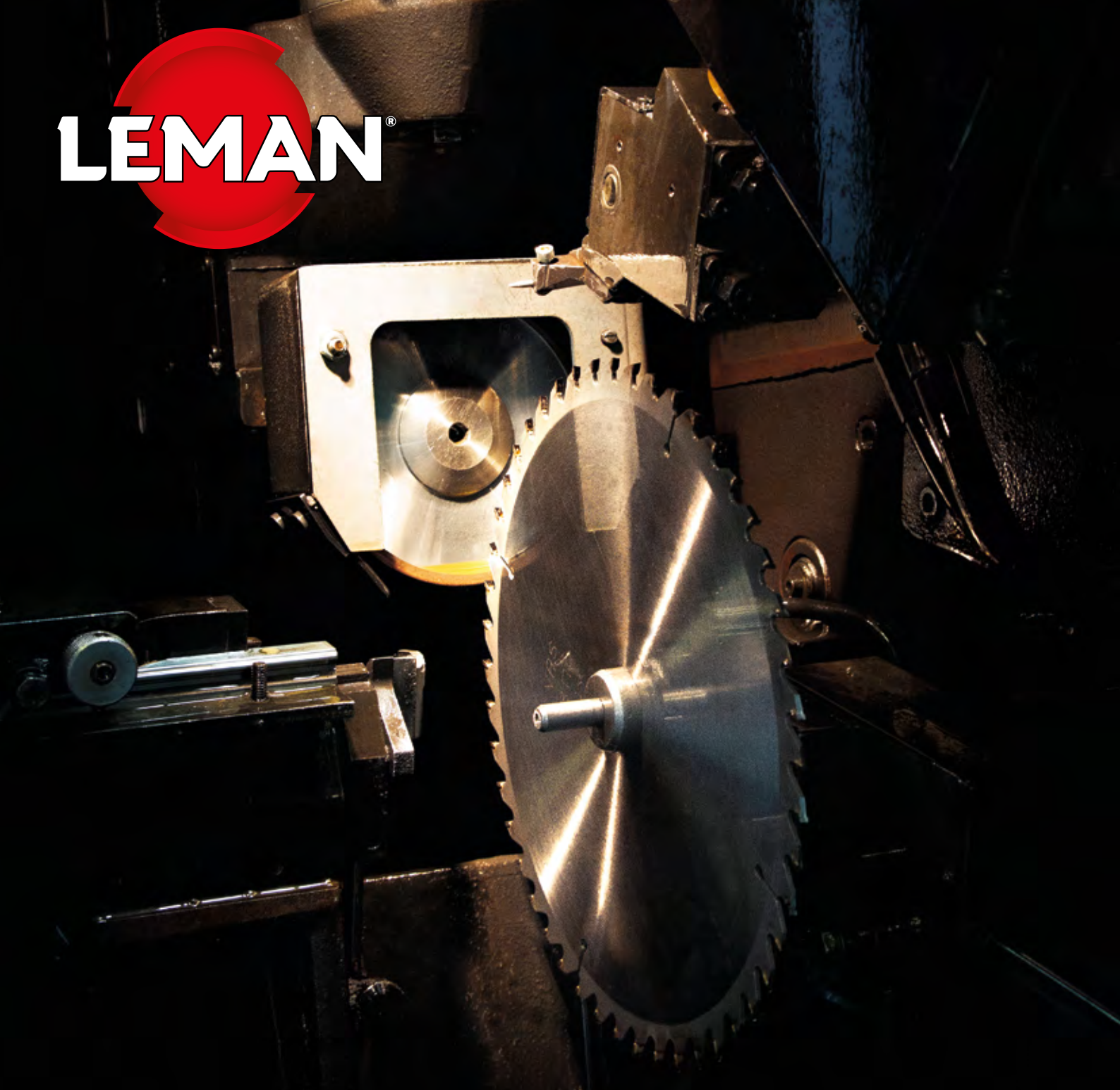

**LEMAN**<sup>®</sup>



*Selectie* **2023**  
**EXPERT HOUT**



# LEMAN's selection special expert wood



**CIRKELZAAGBLADEN**

**PAGE 4**



**MESSEN EN SNIJPLATEN**

**PAGE 18**



**ROUTERGEREEDSCHAP**

**PAGE 22**



**CNC-BEWERKINGSMACHINES**

**PAGE 31**



**DRAAIBANK EN BEITELS**

**PAGE 34**



**ACCESORIES**

**PAGE 37**



**LINTZAAGBLADEN**

**PÁGINA 38**

# CHECK OUT OUR **WEBSITE!**

[www.leman-sa.com](http://www.leman-sa.com)



- Find technical information on our **8000** references and our **18** product ranges.
- **Handling tips and recommendations** provided by our experts
- Updated **catalogs**...and many other services.

## **FOLLOW US** on **SOCIAL MEDIA**

TO DISCOVER THE INCREDIBLE CREATIONS OF OUR EXPERT CRAFTSMEN PARTNERS  
and take advantage of **EXCLUSIVE BENEFITS!**



# CIRKELZAAGBLADEN

CLASSIC



CV

EN847-1

## LSC.966KV

### STALEN ZAAGBLAD VOOR HET ZAGEN VAN BRANDHOUT & VERS HOUT

- Stalen zaagblad voor op afmeting zagen en zagen van brandhout.
- Haakvertanding, geslepen en gezet.
- Gaten voor dwarsstiften tot Ø 450 2/10/60.
- Gaten voor dwarsstiften vanaf Ø 500 2/12/72.

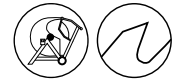

HOUT, BRANDHOUT

Ø	mm	mm	Z	REF	Icon	Barcode
450	30	4,1/2,5	56	<b>966.450.2556</b>	1	3510789660311
500	30	4,1/2,5	56	<b>966.500.2556</b>	1	3510789660816
500	30	5,0/3,0	56	<b>966.500.3056</b>	1	3510789660335
600	30	4,6/2,8	56	<b>966.600.2856</b>	1	3510789660823

CLASSIC



CV

EN847-1

## LSC.966NVL

### STALEN SNOEIBLAD VOOR MAAIBALK

- Voor snoeiwerkzaamheden.
- Puntvertanding, geslepen en gezet.
- Gaten voor dwarsstiften 2/18/120.

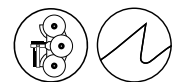

HOUT, BRANDHOUT

Ø	mm	mm	Z	REF	Icon	Barcode
600	45	6,6/4,0	96	<b>966.600.40.4596</b>	1	3661589064646
700	45	6,6/4,0	96	<b>966.700.40.4596</b>	1	3661589064653
700	50	6,6/4,0	96	<b>966.700.40.5096</b>	1	3661589072870

CLASSIC



HM

EN847-1

LSC.00222  
ZAAGBLAD VOOR MASSIEF TIMMERHOUT

- Zaagblad met anti-terugslag.
- Speciaal ontworpen voor het in de lengte en breedte zagen van alle soorten natuurlijk hout en brandhout.
- Gaten voor dwarsstiften gecombineerd 2/7/42 + 2/9/46,4 + 2/10/60.
- Extra gaten voor dwarsstiften 2/12/72 vanaf Ø 500.

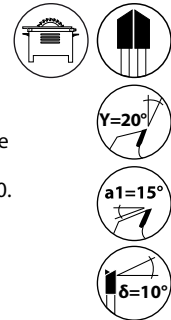

HOUT, BRANDHOUT

Ø	mm	mm	Z	REF	Icon	Barcode
250	30	3,2/2,2	24	<b>222.250.3024</b>	1	3510782221007
300	30	3,2/2,2	28	<b>222.300.3028</b>	1	3510782221014
315	30	3,2/2,2	24	<b>222.315.3024</b>	1	3510782221076
350	30	3,5/2,5	32	<b>222.350.3032</b>	1	3510782221021
400	30	3,5/2,5	36	<b>222.400.3036</b>	1	3510782221038
450	30	4,0/2,8	32	<b>220.450.3032</b>	1	3510782201054
500	30	4,0/2,8	36	<b>220.500.3036</b>	1	3510782201061
600	30	4,0/2,8	40	<b>220.600.3040</b>	1	3510782201078
700	30	4,4/3,2	46	<b>220.700.3046</b>	1	3510782201085

CLASSIC



HM

EN847-1

LSC.00215  
ZAAGBLAD VOOR MASSIEF TIMMERHOUT

- Zaagblad voor kantrechten, anti-terugslag en met schrapers, voor het zagen van dik, groen en vochtig hout.
- Gaten voor dwarsstiften gecombineerd 2/7/42 + 2/9/46,4 + 2/10/60.

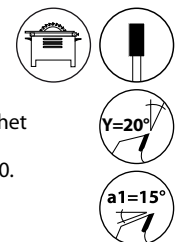

HOUT

Ø	mm	mm	Z	REF	Icon	Barcode
250	30	3,2/2,2	18 + 3	<b>215.250.3018</b>	1	3510782150017
300	30	3,2/2,2	18 + 3	<b>215.300.3018</b>	1	3510782150024
350	30	3,6/2,5	20 + 4	<b>215.350.3020</b>	1	3510782150031
400	30	4,0/2,8	24 + 4	<b>215.400.3024</b>	1	3510782150048

# CIRKELZAAGBLADEN

CLASSIC



HM

EN847-1

LSC.00328

## ZAAGBLAD VOOR HET OP MAAT ZAGEN VAN MASSIEF HOUT EN HOUTPLATEN

- Universeel gebruik, voor het in de lengte en breedte zagen van zacht en hard hout, tropisch hout, aan één zijde gelamineerde platen en laminaat.
- Gatens voor dwarsstiften gecombineerd 2/7/42 + 2/9/46,4 + 2/10/60.

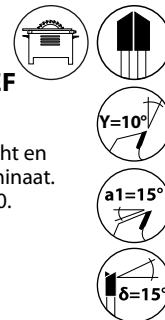

HOUT

Ø	Ø	Ø	Z	REF	Icon	Icon
250	30	3,2/2,2	40	<b>328.250.3040</b>	1	3510783261019
250	30	3,2/2,2	48	<b>334.250.3048</b>	1	3510783261026
300	30	3,2/2,2	48	<b>328.300.3048</b>	1	3510783261057
300	30	3,2/2,2	60	<b>334.300.3060</b>	1	3510783261064
315	30	3,2/2,2	48	<b>328.315.3048</b>	1	3510783261071
350	30	3,5/2,5	54	<b>328.350.3054</b>	1	3510783261095
400	30	3,5/2,5	60	<b>328.400.3060</b>	1	3510783261125

CLASSIC



HM

EN847-1

LSC.964BAN

## ZAAGBLAD VOOR ALLE SOORTEN ZAGEN VOOR MASSIEF HOUT

- Wisselende vertanding, voor hout.
- Zaagbladen tot 235 mm worden geleverd met reduceerringen.
- Asgat 20 (20/16 + 20/12,7) en asgat 30 (30/16 + 30/20).

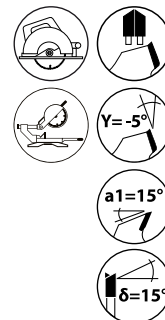

HOUT, HOUTEN LATTEN, MULTIPLEX

Ø	Ø	Ø	Z	REF	Icon	Icon
160	20	2,5/1,6	48	<b>964.160.2548</b>	1	3510789642539
216	30	2,8/1,8	24	<b>964.216.3024</b>	1	3510789641723
216	30	2,8/1,8	48	<b>964.216.3048</b>	1	3510789641730
260	30	2,5/1,8	48	<b>964.260.2548</b>	1	3510789642713
260	30	2,5/1,8	60	<b>964.260.2560</b>	1	3510789642720
305	30	3,2/2,2	32	<b>964.305.3032</b>	1	3510789642591
305	30	3,2/2,2	60	<b>964.305.3060</b>	1	3510789642607

CLASSIC



HM

EN847-1

**LSC.964BA**

**ZAAGBLAD VOOR ALLE SOORTEN ZAGEN VOOR MASSIEF HOUT**

- Wisselende vertanding, voor hout.
- Zaagbladen tot 235 mm worden geleverd met reduceerringen. Asgat 20 (20/16 + 20/12,7) en asgat 30 (30/16 + 30/20).

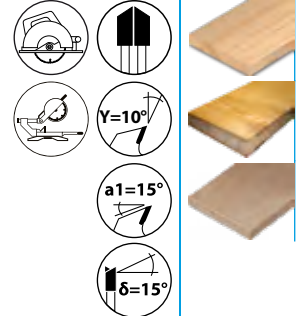

HOUT, HOUTEN LATTEN, MULTIPLEX

				REF		
160	20	1,8/1,2	24	<b>964.160.1824</b>	1	3510789641297
160	20	1,8/1,2	48	<b>964.160.1848</b>	1	3510789641396
160	20	2,2/1,6	24	<b>964.160.2224</b>	1	3661589043146
160	20	2,2/1,6	48	<b>964.160.2248</b>	1	3510789641990
160	20	2,2/1,6	60	<b>964.160.2260</b>	1	3661589086747
160	20	2,5/1,6	24	<b>964.160.2024</b>	1	3510789641235
160	20	2,5/1,6	48	<b>964.160.2048</b>	1	3510789641259
168	20	1,8/1,2	24	<b>964.168.1824</b>	1	3661589099778
168	20	1,8/1,2	48	<b>964.168.1848</b>	1	3661589099785
190	30	2,8/1,8	24	<b>964.190.3024</b>	1	3510789641570
190	30	2,8/1,8	48	<b>964.190.3048</b>	1	3510789641587
210	30	2,8/1,8	24	<b>964.210.3024</b>	1	3510789641679
210	30	2,8/1,8	48	<b>964.210.3048</b>	1	3510789641686
230	30	2,8/1,8	24	<b>964.230.3024</b>	1	3510789641808
230	30	2,8/1,8	48	<b>964.230.3048</b>	1	3510789641815
235	30	2,8/1,8	24	<b>964.235.3024</b>	1	3510789642157
235	30	2,8/1,8	48	<b>964.235.3048</b>	1	3510789642164
255	30	3,2/2,2	40	<b>964.255.3040</b>	1	3510789642645
255	30	3,2/2,2	60	<b>964.255.3060</b>	1	3510789642652

# CIRKELZAAGBLADEN

EXPERT



HM  
MICROGRAIN

EN847-1

## LSC.E0003

### ZAAGBLAD VOOR HET OP MAAT ZAGEN VAN HOUTPLATEN

- Zaagblad voor natuurlijk, zacht, hard en tropisch hout.
- Aan een kant gelamineerde platen of laminaat, zaagsnede tot 30 mm hoog.
- Stille slijptol met lasersnedes.
- Snijplaten carbide micro-korrel.
- Gaten voor dwarsstiften gecombineerd 2/7/42 + 2/9/46,4 + 2/10/60.

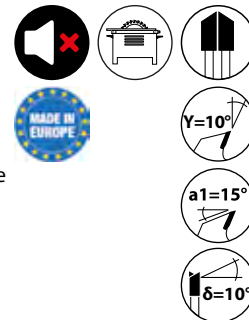

#### HOUT, HOUTEN LATTEN, MULTIPLEX, SPAANPLAAT

Ø	Ø	Ø	Z	REF	Icon	Icon
250	30	3,2/2,2	64	<b>GOLD3.2503060</b>	1	3510786000110
250	30	3,2/2,2	72	<b>GOLD3.2503080</b>	1	3510786000127
300	30	3,2/2,2	72	<b>GOLD3.3003072</b>	1	3510786000134
300	30	3,2/2,2	96	<b>GOLD3.3003096</b>	1	3510786000141
350	30	3,6/2,5	108	<b>GOLD3.3503010</b>	1	3510786000158

CLASSIC



HM

EN847-1

## LSC.964TF

### ZAAGBLAD VOOR ALLES SOORTEN ZAGEN VOOR HOUTPLATEN

- Voor afwerking.

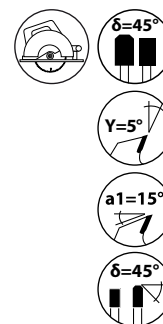

#### PARKETVLOEREN, HPL (HIGH PRESSURE LAMINATE), MELAMINE, LAMINAAT, MDF/HDF

Ø	Ø	Ø	Z	REF	Icon	Icon
120	20	1,8/1,2	40	<b>964TF.120.40</b>	1	3510785435074
160	20	1,8/1,2	48	<b>964TF.160.46</b>	1	3661589107718
160	20	2,2/1,6	48	<b>964TF.160.47</b>	1	3510785402014
160	20	2,5/1,6	48	<b>964TF.160.48</b>	1	3510789642553
165	20	2,2/1,6	48	<b>964TF.165.48</b>	1	3661589107725
190	30	2,4/1,6	56	<b>964TF.190.56</b>	1	3661589107732
235	30	2,4/1,6	54	<b>964TF.235.64</b>	1	3661589107749



CLASSIC



HM

EN847-1

**LSC.964TFN**  
**CIRKELZAAGBLAD VOOR VERSTEKMACHINES**

- Voor afwerking.

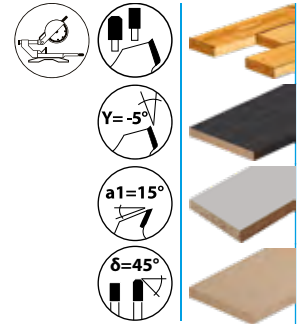

PARKETVLOEREN, HPL (HIGH PRESSURE LAMINATE), MELAMINE, LAMINAAT, MDF/HDF

				REF		
210	30	2,4/1,6	60	<b>964TFN.210.60</b>	1	3661589107756
216	30	2,4/1,6	64	<b>964TFN.216.64</b>	1	3661589107763
255	30	2,5/1,8	72	<b>964TFN.255.72</b>	1	3661589107770
260	30	2,5/1,8	72	<b>964TFN.260.72</b>	1	3661589107787
305	30	3,0/2,0	84	<b>964TFN.305.84</b>	1	3661589107794

CLASSIC



HM

EN847-1

**LSC.00338**  
**ZAAGBLAD VOOR HET OP MAAT ZAGEN VAN HOUTPLATEN**

- Universeel gebruik, voor het in de lengte en breedte zagen van zacht en hard hout, tropisch hout, aan één zijde gelamineerde platen en laminaat.
- Gaten voor dwarsstiften gecombineerd 2/7/42 + 2/9/46,4 + 2/10/60.

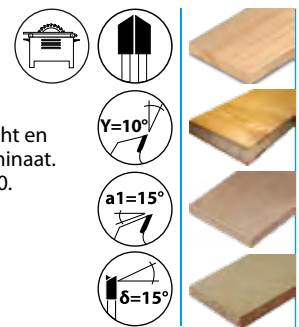

HOUT, HOUTEN LATTEN, MULTIPLEX, SPAANPLAAT

				REF		
250	30	3,2/2,2	60	<b>336.250.3060</b>	1	3510783361009
250	30	3,2/2,2	80	<b>338.250.3080</b>	1	3510783381007
300	30	3,2/2,2	72	<b>336.300.3072</b>	1	3510783361016

# CIRKELZAAGBLADEN

EXPERT



HM  
MICROGRAIN

EN847-1

## LSC.E04TF EDGE BANDER BLADE FOR PANELS MADE FROM WOOD

- Zaagblad.
- Optimale zaagkwaliteit in massieve plastic panelen (thermoplastisch en duroplastisch), laminaat en MDF.
- Stille slijptol met lasersnedes.
- Snijplaten carbide micro-korrel.
- Gaten voor dwarsstiften gecombineerd 2/7/42 + 2/9/46,4 + 2/10/60.

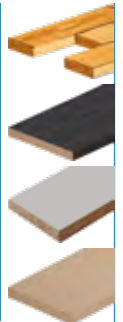
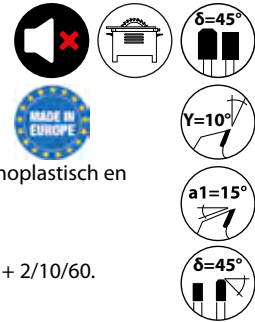

PARKETVLOEREN, HPL (HIGH PRESSURE LAMINATE), MELAMINE, LAMINAAT, MDF/HDF

				REF		
250	30	3,2/2,2	80	<b>GOLD4.2503080</b>	1	3510786000189
300	30	3,2/2,2	96	<b>GOLD4.3003096</b>	1	3510786000202

CLASSIC



HM

EN847-1

## LSC.338TF ZAAGBLAD VOOR HET OP MAAT ZAGEN VAN HOUTPLATEN

- Voor grof en op maat zagen van een- of tweezijdige panelen, zaagsnede tot 30 mm hoog.
- Optimale zaagkwaliteit in massieve plastic panelen (thermoplastisch en duroplastisch), laminaat.
- Gaten voor dwarsstiften gecombineerd 2/7/42 + 2/9/46,4 + 2/10/60.

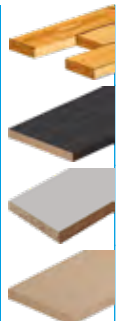
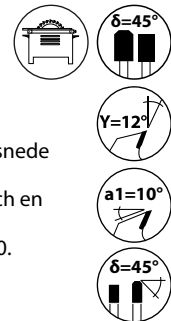

PARKETVLOEREN, HPL (HIGH PRESSURE LAMINATE), MELAMINE, LAMINAAT, MDF/HDF

				REF		
220	30	3,2/2,2	64	<b>338TF.220.64</b>	1	3510783382004
250	30	3,2/2,2	60	<b>336TF.250.60</b>	1	3510783362006
250	30	3,2/2,2	80	<b>338TF.250.80</b>	1	3510783382011
300	30	3,2/2,2	72	<b>336TF.300.72</b>	1	3510783362013
300	30	3,2/2,2	96	<b>338TF.300.96</b>	1	3510783382028
350	30	3,5/2,5	84	<b>336TF.350.84</b>	1	3510783362020
350	30	3,5/2,5	10	<b>338TF.350.10</b>	1	3510783382035

EXPERT



HM  
MICROGRAIN

EN847-1

**LSC.E0005**  
**ZAAGBLAD VOOR HET OP MAAT ZAGEN VAN MELAMINE & LAMINAAT**

- Zaagblad voor het zagen van met thermoplastisch en duroplastisch polyester beplakte platen.
- Gecoate platen, zaagsnede tot 50 mm hoog, en MDF.
- Stille slijptol met lasersnedes.
- Snijplaten carbide micro-korrel. Gebruik zonder voorritsblad mogelijk.
- Gaten voor dwarsstiften gecombineerd 2/7/42 + 2/9/46,4 + 2/10/60.

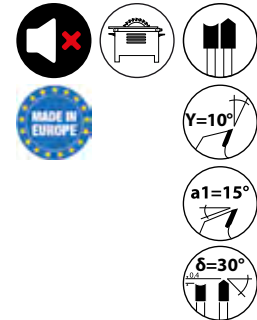

MELAMINE, LAMINAAT, MDF/HDF

				REF		
250	30	3,2/2,2	48	<b>GOLD5.2503048</b>	1	3510786000233
303	30	3,2/2,2	60	<b>GOLD5.3033061</b>	1	3510786000257

EXPERT



HM  
MICROGRAIN

EN847-1

**LSC.E0005N**  
**ZAAGBLAD VOOR HET OP MAAT ZAGEN VAN MELAMINE & LAMINAAT**

- Zaagblad voor het zagen van met thermoplastisch en duroplastisch polyester beplakte platen.
- Gecoate platen, zaagsnede tot 50 mm hoog, en MDF.
- Stille slijptol met lasersnedes.
- Snijplaten carbide micro-korrel. Gebruik zonder voorritsblad mogelijk.
- Gaten voor dwarsstiften gecombineerd 2/7/42 + 2/9/46,4 + 2/10/60.

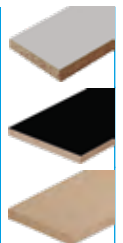
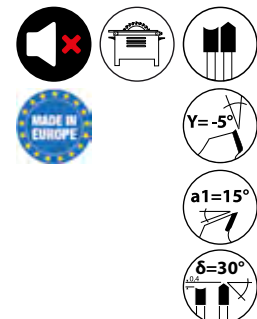

MELAMINE, LAMINAAT, MDF/HDF

				REF		
303	30	3,2/2,2	60	<b>GOLD5.3033060</b>	1	3510786000240

# CIRKELZAAGBLADEN

CLASSIC



HM

EN847-1

## LSC.00354 ZAAGBLAD VOOR HET OP MAAT ZAGEN VAN MELAMINE EN LAMINAAT

- Excellente kwaliteit van de zaagsnedes in met thermoplastisch en duroplastisch polyester beplakte platen.
- Gecoate platen, zaagsnede tot 50 mm hoog.
- Gebruik zonder voorritsblad mogelijk.
- Gaten voor dwarsstiften gecombineerd 2/7/42 + 2/9/46,4 + 2/10/60.

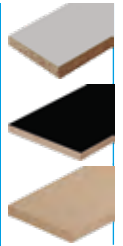
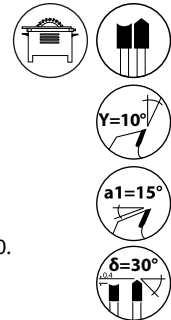

MELAMINE, LAMINAAT, MDF/HDF

Ø	Ø	Ø	Z	REF	Icon	Icon
220	30	3,2/2,2	40	<b>354.220.3040</b>	1	3510783541005
250	30	3,2/2,2	48	<b>354.250.3048</b>	1	3510783541012
303	30	3,2/2,2	60	<b>354.303.3061</b>	1	3510783541036

CLASSIC



HM

EN847-1

## LSC.00354N ZAAGBLAD VOOR HET OP MAAT ZAGEN VAN MELAMINE EN LAMINAAT

- Excellente kwaliteit van de zaagsnedes in met thermoplastisch en duroplastisch polyester beplakte platen.
- Gecoate platen, zaagsnede tot 50 mm hoog.
- Gebruik zonder voorritsblad mogelijk.
- Gaten voor dwarsstiften gecombineerd 2/7/42 + 2/9/46,4 + 2/10/60.

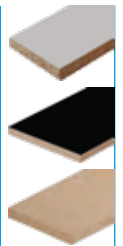
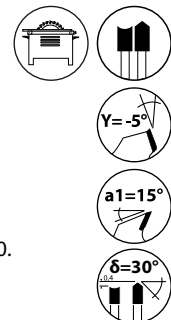

MELAMINE, LAMINAAT, MDF/HDF

Ø	Ø	Ø	Z	REF	Icon	Icon
303	30	3,2/2,2	60	<b>354.303.3060</b>	1	3510783541029

CLASSIC



HM  
PLAQUETTES

EN847-1

## LSC.LAM.PO0938HM GEREEDSCHAPSHOUDER VOOR KLEPMONTAGE

- Freesblok met omkeerbare platen van hardmetaal.
- Anti-afstotingsvorm.
- Gefreesde behuizing met verstevigd centrum.
- Reserveonderdelen : haakvormige platen 0018.1819.00 - platen 02.2171.4.

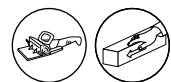

HOUTEN LATTEN, MULTIPLEX, HPL (HIGH PRESSURE LAMINATE), MDF/HDF, MELAMINE

Ø	Ø	Ø	Z	REF	Icon	Icon
100	22	3,96	Z=2+2 + V=2+2	<b>938.9.100.22.44</b>	1	3510789381032

CLASSIC



PCD

HM

EN847-1

LSC.DI350TF

MULTIMATERIAAL DIAMANT CIRKELZAAGBLAD VOOR DRAAGBARE EN STATIONAIRE MACHINES

- Zagen van schurende materialen en composiet.
- Robuuste diamantsnijplaat.
- Stille slijptol met lasersnedes.

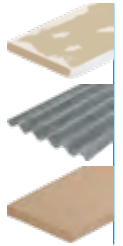
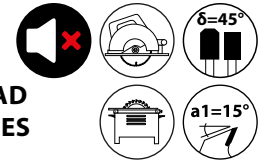

VEZELCEMENT, MATERIALEN OP CEMENTBASIS, GIPS, MDF/HDF

				REF		
160	20	1,8/1,4	8	<b>350TF.160.1808</b>	1	3661589108012
160	20	2,2/1,6	8	<b>350TF.160.2208</b>	1	3661589108029
190	30	2,2/1,6	10	<b>350TF.190.3010</b>	1	3661589108036
230	30	2,2/1,6	15	<b>350TF.230.3015</b>	1	3661589108043
250	30	2,4/1,8	16	<b>350TF.250.3016</b>	1	3661589108050

CLASSIC



PCD

HM

EN847-1

LSC.DI350TFN

MULTIMATERIAAL DIAMANT CIRKELZAAGBLAD VOOR DRAAGBARE EN VERSTEKMACHINES

- Zagen van schurende materialen en composiet.
- Robuuste gediamanteerde snijplaat.
- Stille slijptol met lasersnedes.

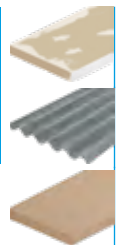
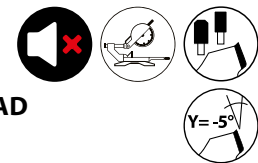

VEZELCEMENT, MATERIALEN OP CEMENTBASIS, GIPS, MDF/HDF

				REF		
216	30	2,2/1,6	12	<b>350TFN.216.3012</b>	1	3661589108067
255	30	2,4/1,8	18	<b>350TFN.255.3018</b>	1	3661589108074
260	30	2,4/1,8	18	<b>350TFN.260.3018</b>	1	3661589108081
305	30	2,4/1,8	24	<b>350TFN.305.3024</b>	1	3661589108302

# CIRKELZAAGBLADEN

EXPERT



HM  
MICROGRAIN

**EN847-1**

## LSC.E0011 ZAAGBLAD VOOR DROOG ZAGEN VAN FERROMETALEN

- Zaagblad voor het zagen van hoekprofielen, metalen buizen en platen, vierkante buizen, strips, staven, metalen randen, sandwich panelen.
- Lange levensduur dankzij speciale ontwerp en behandeling van het zaagblad.
- Stille slijptol met lasersnedes.
- Snijplaten carbide micro-korrel.
- Neem de aangegeven maximale snelheid in acht.

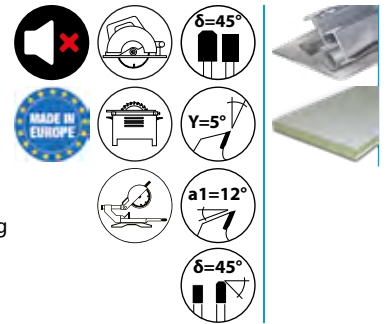

### METAAL, STAAL, MULTILAGIGE - OF SANDWICHMATERIALEN

					REF		
300	30	2,2/1,8	60	1500	<b>GOLD11.3003060</b>	1	3510785435005
305	25,4	2,2/1,8	60	1500	<b>GOLD11.3052560</b>	1	3510785435012
320	25,4	2,2/1,8	72	1900	<b>GOLD11.3202572</b>	1	3661589079046
350	30	2,4/2,0	72	1200	<b>GOLD11.3503072</b>	1	3510785435029
355	25,4	2,4/2,0	72	1200	<b>GOLD11.3552572</b>	1	3510785435036



CLASSIC



HM

EN847-1

**LSC.00120**  
**ZAAGBLAD VOOR DROOG ZAGEN VAN**  
**FERROMETALEN**

- Voor hoekprofielen, metalen buizen en platen, vierkante buizen, strips, staven, metalen randen, sandwich panelen.
- Voor draagbare en vaste machines, dry cutter met lage rotatiesnelheid.
- Snelle zaagsnede, schoon, zonder splinters, zonder verhitting.

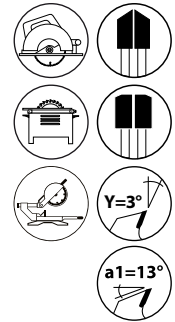

**METAAL, STAAL, MULTILAGIGE - OF SANDWICHMATERIALEN**

Ø	Ø	↓	Z	↻	REF	☑	📊
136	20	1,5/1,2	30	3000	<b>120.136.2030</b>	1	3661589079138
160	20	2,2/1,6	30	3000	<b>120.160.2030</b>	1	3510781202038
180	20	2,2/1,6	36	3000	<b>120.180.2034</b>	1	3510781202052
180	30	2,2/1,6	36	3000	<b>120.180.3034</b>	1	3510781202069
190	30	2,4/1,8	38	3000	<b>120.190.3038</b>	1	3510781202083
230	30	2,4/1,8	44	2000	<b>120.230.3044</b>	1	3510781202120
250	30	2,4/2,0	48	1750	<b>120.250.3048</b>	1	3510781202137
305	25,4	2,4/2,0	60	1500	<b>120.300.2560</b>	1	3510781202144
305	25,4	2,4/2,0	80	1200	<b>120.300.2580</b>	1	3510781202175
355	25,4	2,6/2,2	80	1200	<b>120.355.2580</b>	1	3510781202205

CLASSIC



HM

EN847-1

**LSC.112AL**  
**ZAAGBLAD VOOR NON - FERROMETALEN**

- Voor het zagen van dunne aluminium en plastic randen, omlijstingen en aluminium platen.
- Handmatige aanvoer.
- Zaag voor radiaalzagen.
- Asgat 40 : gaten voor dwarsstiften 2/9/55 + 4/12/64.
- Gaten voor dwarsstiften gecombineerd 2/10/60 + 2/11/63 + 2/12/64.

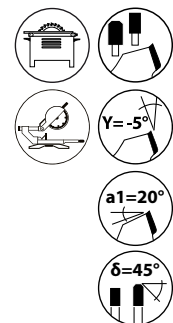

**ALUMINIUM, NON-FERROMETALEN, PVC, PLASTIC MATERIALEN**

Ø	Ø	↓	Z	REF	☑	📊
250	30	3,2/2,2	80	<b>112.250.3080</b>	1	3510781121032
300	30	3,2/2,5	96	<b>112.300.3096</b>	1	3510781121100
350	30	3,4/2,8	108	<b>112.350.3010</b>	1	3510781121216
350	32	3,4/2,8	108	<b>112.350.3210</b>	1	3510781121223
400	30	3,8/3,2	120	<b>112.400.3012</b>	1	3510781121186

# CIRKELZAAGBLADEN

CLASSIC



HM

EN847-1

## LSC.964AL

### ZAAGBLAD VOOR NON - FERROMETALEN

- Zaagbladen tot 235 mm worden geleverd met reduceerringen.  
Asgat 20 (20 / 16 + 20 / 12,7) en asgat 30 (30 / 16 + 30 / 20).

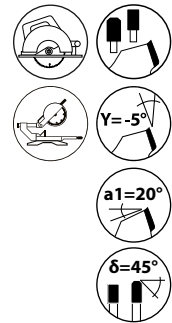

#### ALUMINIUM, NON-FERROMETALEN, PVC, PLASTIC MATERIALEN

				REF		
160	20	2,5/1,8	42	<b>964.160.20AL</b>	1	3510789641266
160	20	2,2/1,6	48	<b>964.160.48AL</b>	1	3661589043160
190	30	2,8/2,0	54	<b>964.190.30AL</b>	1	3510789642560
210	30	2,8/2,0	54	<b>964.210.30AL</b>	1	3510789641716
216	30	2,8/2,0	60	<b>964.216.30AL</b>	1	3510789641747
230	30	2,8/2,0	62	<b>964.230.30AL</b>	1	3510789641839
235	30	2,8/2,0	62	<b>964.235.30AL</b>	1	3510789642461
255	30	3,2/2,3	80	<b>964.255.30AL</b>	1	3510789642669
260	30	2,5/1,8	80	<b>964.260.25AL</b>	1	3510789642737
305	30	3,2/2,5	80	<b>964.305.80AL</b>	1	3510789642614



CLASSIC



HSS  
DM05

FSC.00122

**ZAAGFREES VOOR HET ZAGEN VAN STAAL**

- Hardheid 63 / 64 Hrc.
- Stoombehandeling.
- Frezen worden geleverd met standaard aandrijfgaten.



**METAAL, STAAL, FERROMETALENZ**

KEUZE TANDSTEEK EN TANDVORM		
<b>TANDSTEEK 3 MM</b>	Voor fijne buizen en profielen met een dikte van 1 tot 2 mm.	
<b>TANDSTEEK 4 MM</b>	Voor dunne staven, buizen en profielen met een dikte van 2 tot 4 mm.	
<b>ACME TANDVORM (T3/4/5)</b>	De tanden staan op dezelfde hoogte en worden afwisselend links en rechts afgeschuind.	
<b>HELLER TANDVORM (T6 / 8 / 10)</b>	Elke tweede tand is aan beide zijden afgeschuind (voorruwende tand) en is hoger dan de volgende tand (afwerktaand) die recht is.	
<b>TANDSTEEK 5 MM</b>	Voor middelgrote profielen, buizen en materiaal van 4 tot 15 mm dik.	
<b>TANDSTEEK 6 MM</b>	Voor dikke profielen, buizen en materiaal van 15 tot 30 mm dikte.	
<b>TANDSTEEK 8 MM</b>	Voor dik materiaal tot 60 mm dikte.	
<b>TANDSTEEK 10 MM (T10) AND MORE</b>	Voor zeer dik materiaal en massieve profielen van 60 mm en meer.	

STANDAARD ASGATEN		
ASGAT	CODE ASGAT	AFMETINGEN
32	MX	2/8/45 + 2/11/63
40	RG	2/8/55 + 4/12/64

						REF		
315	32	2,5	240	4	<b>122.314.2532</b>	1	3510781221497	
315	32	2,5	200	5	<b>122.315.2532</b>	1	3510781221503	
315	32	2,5	160	6	<b>122.316.2532</b>	1	3510781221510	
315	32	2,5	120	8	<b>122.318.2532</b>	1	3510781221527	

# MESSEN EN SNIJPLATEN

EXPERT



HSS

**FPL.00145**  
**REVERSIBELESCHAAFMESSEN HSS - « TERSA® » - SYSTEEM**

- Snijplaten carbide, andere afmetingen op bestelling.



HOUT						
			<b>Z</b>	REF		
230	10	2,3	2	<b>145.523.00</b>	1	3510785415328
310	10	2,3	2	<b>145.531.00</b>	1	3510785415366
410	10	2,3	2	<b>145.541.00</b>	1	3510785415380
500	10	2,3	2	<b>145.550.00</b>	1	3510785417759
510	10	2,3	2	<b>145.551.00</b>	1	3510785417261
520	10	2,3	2	<b>145.552.00</b>	1	3510785415397
610	10	2,3	2	<b>145.561.00</b>	1	3510785415403
630	10	2,3	2	<b>145.563.00</b>	1	3510785415410
640	10	2,3	2	<b>145.564.00</b>	1	3510785415427

EXPERT

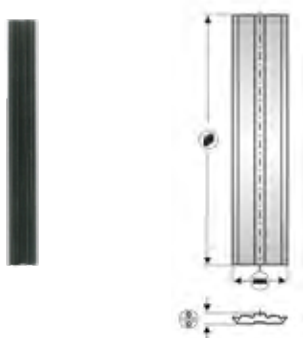

HSS

**FPL.00147**  
**REVERSIBELE SCHAAFMESSEN HSS BLACK OXIDE**  
**« CENTROFIX® » SYSTEEM**

- Snijplaten carbide, andere afmetingen op bestelling.



HOUT						
			<b>Z</b>	REF		
260	12	2,7	2	<b>147.526.00</b>	1	3661589035585
310	12	2,7	2	<b>147.531.00</b>	1	3661589035592
410	12	2,7	2	<b>147.541.00</b>	1	3661589035608

CLASSIC



HSS  
18%

**FPL.00243**

**SCHAAFMESSEN VOOR SCHAAFMACHINE 18 %**

- In het bijzonder geschikt voor knoestig hout.
- Geleverd in plastic hoes.
- Geschikt voor het snijden van tussen-afmetingen.

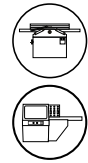

							HOUT
				Z	REF		
250	30	3	1	<b>025.30.302</b>	1	3510785417339	
260	20	2,5	1	<b>026.20.252</b>	1	3510781301106	
260	20	3	1	<b>026.20.302</b>	1	3510781301113	
260	25	3	1	<b>026.25.302</b>	1	3510781301137	
300	30	3	1	<b>030.30.302</b>	1	3510781301151	
310	20	2,5	1	<b>031.20.252</b>	1	3510781301168	
310	25	3	1	<b>031.25.302</b>	1	3510781301175	
310	30	3	1	<b>031.30.302</b>	1	3510781301182	
410	25	2,5	1	<b>041.25.252</b>	1	3510781301236	
410	25	3	1	<b>041.25.302</b>	1	3510781301243	
410	30	3	1	<b>041.30.302</b>	1	3510781301267	
500	30	3	1	<b>050.30.302</b>	1	3510785417063	
510	25	3	1	<b>051.25.302</b>	1	3510781301342	
510	30	3	1	<b>051.30.302</b>	1	3510781301366	
520	30	3	1	<b>052.30.302</b>	1	3510781301410	
630	30	3	1	<b>063.30.302</b>	1	3510781301557	
640	30	3	1	<b>064.30.302</b>	1	3510781301564	

EXPERT

**FPL.02.40.10**  
**OMKEERBARE SNIJPLATEN CARBIDE 35°- K01**

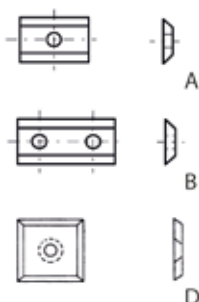

K01

HOUT, MELAMINE

Réf. schéma					REF		
A	7,5	12	1,5	2	<b>02.4001.2</b>	10	3510785424535
A	9,6	12	1,5	2	<b>02.4015.2</b>	10	3510785424610
A	15	12	1,5	2	<b>02.4003.2</b>	10	3510785424559
A	20	12	1,5	2	<b>02.4004.2</b>	10	3510785424566
B	30	12	1,5	2	<b>02.4005.2</b>	10	3510785424573
B	40	12	1,5	2	<b>02.4014.2</b>	10	3510785424603
B	50	12	1,5	2	<b>02.4006.2</b>	10	3510785424580
D	14	14	2	4	<b>02.4099.4</b>	10	3510785417094

CLASSIC

**FPL.02.21.10**  
**OMKEERBARE SNIJPLATEN CARBIDE - K05**

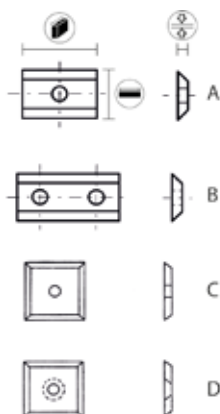

K05

HOUT

Réf. schéma						REF		
A	7,5	12	1,5	2	<b>0765.1215.00</b>	10	3510785417292	
A	9,6	12	1,5	2	<b>0096.1215.00</b>	10	3510785417209	
A	15	12	1,5	2	<b>0015.1215.00</b>	10	3510785417285	
A	20	12	1,5	2	<b>0020.1215.00</b>	10	3510785417056	
B	30	12	1,5	2	<b>0030.1215.00</b>	10	3510785417018	
B	40	12	1,5	2	<b>0040.1215.00</b>	10	3661589034168	
B	50	12	1,5	2	<b>0050.1215.00</b>	10	3510781501094	
C	12	12	1,5	4	<b>0012.1215.00</b>	10	3510785417049	
D	6,8	14	14	2	<b>0014.1420.00</b>	10	3510781511154	
C	8,5	14	14	1,2	<b>02.2171.4</b>	10	3510785417148	
D	6,2	14,3	14,3	2,5	<b>02.2196.4</b>	10	3510785417070	

CLASSIC

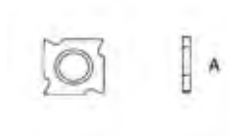

K30

FPL.18.18.10  
OMKEERBARE SNIJPLATEN CARBIDE - K30



HOUT									
Réf. schéma					Z	REF			
A	10	18	18	1,95	4	<b>0018.1819.00</b>	10		351 0785417117
A	10	18	18	2,45	4	<b>0018.1824.00</b>	10		3510785417186
A	10	18	18	2,95	4	<b>0018.1829.00</b>	10		3510785417087

CLASSIC

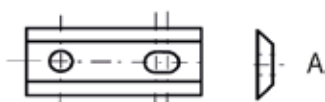

K05

FPL.02.25.10  
OMKEERBARE SNIJPLATEN CARBIDE 35°- K05



HOUT									
Réf. schéma				Z	REF				
A	80	13	2,2	2	<b>0080.1322.00</b>	10			3510785417162

EXPERT



K30

FPL.142.10  
1/6 SCALE ACTION FIGURE

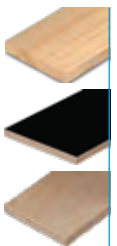

HOUT, LAMINAAT, MULTIPLEX									
			REF						
82	5,5	1,1	<b>142.782.10</b>	1					3510781428827

# ROUTERGEREEDSCHAP 50

EXPERT

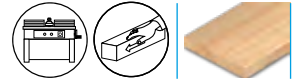

901  
FRAISE À RAINER EXTENSIBLE

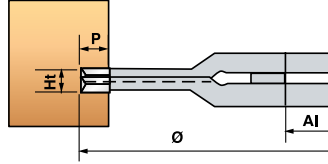

HM

							WOOD
Ø				Z	REF		
160	50	5/10	30	4+V4	<b>901.7.160.50.51</b>	3510785404650	
160	50	10/20	30	4+V4	<b>901.7.160.50.12</b>	3510785404636	

EXPERT

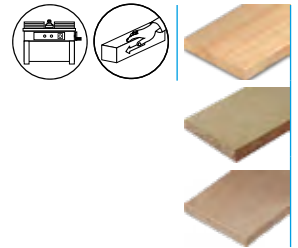

950  
UITSCHUIFBARE CREASE GEREEDSCHAPSHOUDER

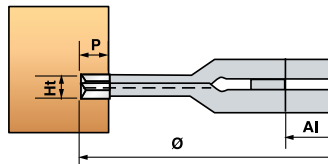

HM  
PLAQUETTES

							HOUT, SPAANPLAAT, MULTIPLEX
Ø				Z	REF		
160	50	4/7,5	30	8+V4	<b>950.9.160.51.47</b>	3510785404506	
160	50	5/9,5	30	8+V4	<b>950.9.160.51.51</b>	3510785402540	
160	50	8/15,5	30	4+V4	<b>950.9.160.51.81</b>	3510785404513	

EXPERT

951  
UITSCHUIFBARE GEREEDSCHAPSHOUDER

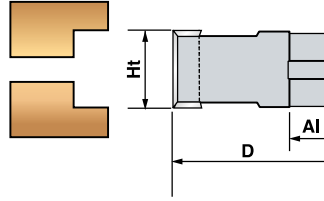
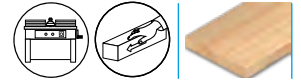

HM  
PLAQUETTES

HOUT

				REF	
160	50	20,4/40	4V4-CD*	<b>951.9.160.51.24</b>	3510785403714
160	50	30,6/60	4V4-CB**	<b>951.9.160.51.36</b>	3510785403721
160	50	30,6/60	4V4-CD*	<b>951.9.160.51.36CD</b>	3661589088215
160	50	50,6/100	4V4-CD*	<b>951.9.160.51.51CD</b>	3661589088222

EXPERT

080  
HELICAL SCROLL GEREEDSCHAPSHOUDERS  
EN TE KALIBREREN

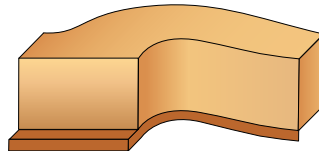
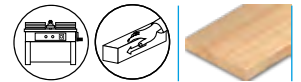

HM  
PLAQUETTES

HOUT

				REF	
80	50	100	16	<b>080.100.50</b>	3510780801003
80	50	120	18	<b>080.120.50</b>	3510780801201

# ROUTERGEREEDSCHAP 50

EXPERT



952

GEREEDSCHAPSHOUDERS OM TE KALBREREN EN TE SPONNEN

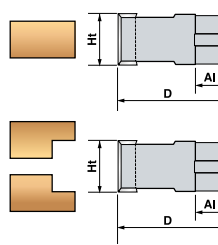
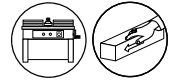

HM  
PLAQUETTES

HOUT

Ø	Ø	Ø	Z	REF	Barcode
125	50	50	4v4	952.9.125.50.44	3510785403677

EXPERT



952

GEREEDSCHAPSHOUDERS OM TE KALBREREN

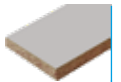
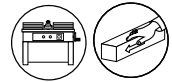

HM  
PLAQUETTES

MELAMINE, HOUT

Ø	Ø	Ø	Z	REF	Barcode
125	50	56	2+2	952.9.125.51.22	3661589088239
125	50	56	3+3	952.9.125.51.33	3661589088246



EXPERT



934

GEREEDSCHAPSHOUDERS MET PLATTE BODEM

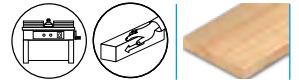

HOUT



140 50 80 2 934.9.140.50.80 3510785435593

HM  
PLAQUETTES

EXPERT



938

GEREEDSCHAPSHOUDERS 45° HOEKBEWEGING ZELFVRIENDELIJK

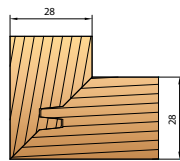
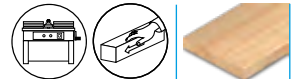

HOUT



180 50 10/30 2+2 938.9.180.50.1030 3661589079640

HM  
PLAQUETTES

EXPERT



908

45° AFSCHUINING GEREEDSCHAPSHOUDER

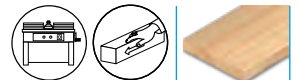

HOUT



120 50 14 2sup 908.9.120.50.05 3661589079640

120 50 14 2inf 908.9.120.50.15 3661589088260

HM  
PLAQUETTES

# ROUTERGEREEDSCHAP 50

EXPERT



**910**  
**KWARTRONDE GEREEDSCHAPSHOUDERS MET**  
**VERWISSELBARE INZETSTUKKEN**

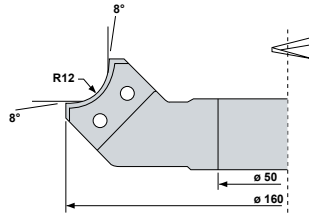
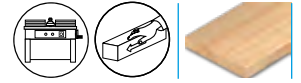

HM  
 PLAQUETTES

HOUT

				REF	
140	50	8/10	2	<b>910.9.140.50.08</b>	3510785405787
160	50	12/15	2	<b>910.9.160.50.12</b>	3510785405794
160	50	20/25	2	<b>910.9.160.50.20</b>	3510785405800
190	50	30/35	2	<b>910.9.190.50.30</b>	3661589088284
200	50	40/42,5	2	<b>910.9.200.50.40</b>	3661589088307

EXPERT



**COFFRET.CALIBRAGE**  
**KALIBRATIEBOX (9 RINGEN + LAGER)**

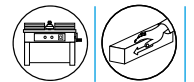

	REF	
95 - 100 - 105 - 110 - 115 - 120 - 125 - 130 - 135 + ROULEMENT Ø 80 - AL50	<b>COFFRET.CALIBRAGE</b>	3661589035400

CLASSIC



HM  
PLAQUETTES

EN847-1

ALE.00662

**FREESBLOKSPIRAALVORMIG**

- Te gebruiken voor kalibreren, uitzagen en kopieerfresen.
- Nauwkeurige en geleidelijke zaagsnede.
- Geleverd met waterdichte kogellager.
- Schrapper (14 x 14 x 2) 0014.1420.00 - schroef M5 x 8 TORX G32.05.006.25.



HOUT					
Ø	Ø	Ø	Z	REF	Barcode
62	30	80	12	662.080.30	3510786628031

CLASSIC



HM  
PLAQUETTES

EN847-1

ALE.00978

**FREESBLOK VOOR VERSTEFREZEN VAN ZAAGTANDEN**

- Voor het samenvoegen van 2 stukken hout waarbij het lijmoppervlak gemaximaliseerd wordt.
- Geleverd met ring met een dikte van 2,5 mm voor het afstellen tussen de 2 insnijdingen.

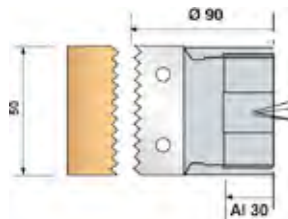

HOUT					
Ø	Ø	Ø	Z	REF	Barcode
90	30	50	2	978.090.30.5000	3510789789050

CLASSIC



HM  
PLAQUETTES

EN847-1

ALE.938.A45

**FREESBLOK VOOR VERSTEFREZEN MET HOEK 45°**

- Hoekverstekfrees en verbindingen 45° voor messing-groefverbindingen.
- Vervaardigen van valse balken, laden en kisten.



HOUT					
Ø	Ø	Ø	Z	REF	Barcode
140	30	13-28	2	938.9.140.30.1328	3661589040626

CLASSIC



HM  
PLAQUETTES

EN847-1

ALE.00075

## FREESBLOK AFSCHUINFREES 45°

- Voor verbindingen van niet-contra-profileerbaar lijstwerk en alle profielen.
- Afschuinen met hoek van 45°.
- Geleverd met M14-schroef met dubbel draad.
- Ook te gebruiken op een as met asgat 50, met schroef M16 (niet meegeleverd).
- Reserveonderdeel schraper (14 x 14 x 2) 0014.1420.00.

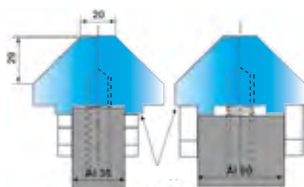

Asmontage ø30 Asmontage ø50



HOUT

			REF	
75/20	29	6	075.45.30	3661589040619

CLASSIC



HM  
PLAQUETTES

EN847-1

ALE.AJ928

## VERSTELBAAR FREESBLOK VOOR SPONNINGFREZEN EN GATEN

- Freesblok voor pennen en sponningen met onder- en boventrimmers.
- Uitbreidingsringen niet meegeleverd.
- Freesblok Ø 150 mm, combineerbaar met Freesblok profiel.
- Reserveonderdeel schraper (14 x 14 x 2) 0014.1420.00, snede (14 x 14 x 2) 0014.1420.00 (20 x 12 x 1,5) 0020.1215.00 en accessoires ALE.AJ928.



HOUT

				REF	
150	30	20-39	4+V4	928.150.30.2039	3510789281516

CLASSIC



**ALE.00948**  
**MULTI-PROFILE BORDER TOOL HOLDER**

- Vervaardigen van 3 verschillende profielen.
- Reversibele snijplaten.
- Geleverd met profiel nr. 1.

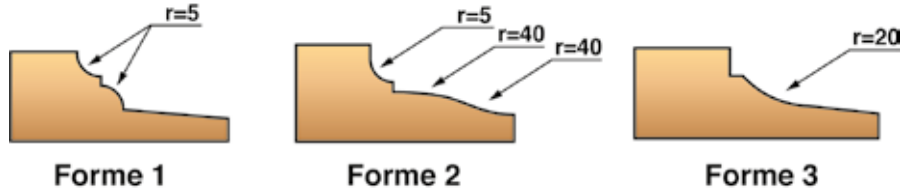

HM  
PLAQUETTES

EN847-1

HOUT						
	Ø	Ø	Ø	Z	REF	Barcode
FROM ABOVE	160	30	20	2	<b>948.160.30.01</b>	3510789481602

CLASSIC



**ALE.00093**  
**FREESBLOK VOOR PROFILEREN EN SPONNINGFREZEN - 50 MM HOOG**

- Sponningfrezes en profileren van massief hout en gelaagde panelen.
- Voor het monteren van alle soorten profielmesses met hoogte 40 en 50 mm.
- Mogelijkheid om te monteren op asachterkant.

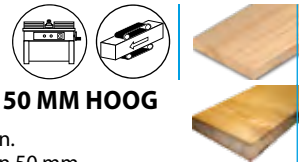

HM  
PLAQUETTES

EN847-1

HOUT, HOUTEN LATTEN						
	Ø	Ø	Ø	Z	REF	Barcode
	100	30	50	2+V2	<b>093.50.30</b>	3510780935036

CLASSIC



**ALE.00123**  
**FREESBLOK VOOR PROFILEREN EN SPONNINGFREZEN - 50 MM HOOG**

- Sponningfrezes en profileren van massief hout en gelaagde panelen.
- Voor het monteren van alle soorten profielmesses met hoogte 40 en 50 mm.
- Onderdelen : 2 snijplaten (50 x 12 x 1,5) 0050.1215.00 - 2 trimmers (14 x 14 x 2) 0014.1420.00.

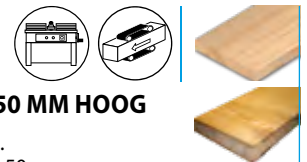

HM  
PLAQUETTES

EN847-1

HOUT, HOUTEN LATTEN						
	Ø	Ø	Ø	Z	REF	Barcode
	120	50	50	2+V2	<b>123.50.50</b>	3510781235050

CLASSIC



EN847-1

ALE.00093.CO

## DOOS MET FRESBLOK VOOR PROFILEREN - 50 MM HOOG

- Doos met 1 freesblok met 2 snijplaten en 2 trimmers.
- Mogelijkheid om te monteren op asachterkant. Montage mogelijk met snijplaten met hoogte 40.
- x 6 paar messen: profielen 203-220-239-275-286-207.
- x 12 paar messen: toevoeging profielen 204- 206-212-225-229-248.
- x 24 paar messen: toevoeging profielen 231-232-260-277-279-280-274-210-236-244-254-255.

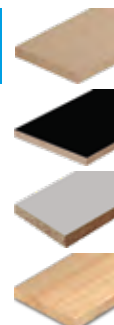

MDF/HDF, LAMINAAT, MELAMINE, HOUT

					REF	
6 PAIRS OF BLADES	100	30	50	2+V2	<b>093.50.30.06</b>	3510780935067
12 PAIRS OF BLADES	100	30	50	2+V2	<b>093.50.30.12</b>	3661589037480

CLASSIC



EN847-1

ALE.00123.CO

## DOOS MET FRESBLOK VOOR PROFILEREN - 50 MM HOOG

- Doos met 1 freesblok met 2 snijplaten en 2 trimmers.
- Montage mogelijk met snijplaten met hoogte 40.
- x 6 paar messen: profielen 203-220-239-275-286-207
- x 12 paar messen: toevoeging profielen 204-206-212-225-229-248.
- x 24 paar messen: toevoeging profielen 231-232-260-277-279-280-274-210-236-244-254-255

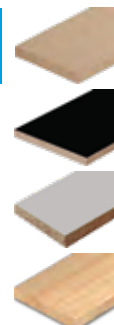

MDF/HDF, LAMINAAT, MELAMINE

					REF	
6 PAIRS OF BLADES	120	50	50	2+V2	<b>123.50.50.06</b>	3661589036001
12 PAIRS OF BLADES	120	50	50	2+V2	<b>123.50.50.12</b>	3661589037503

EXPERT



**890.020**  
**HSK 63F BEVESTIGINGSSYSTEEM**

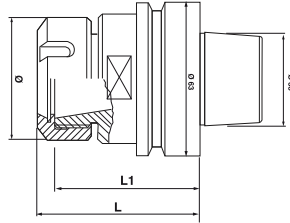

Type	Serrage maxi	L1	L	D	REF	
ER32	20	60	72,5	50	<b>890.020.032</b>	3510785412242
ER40	25	60	76,5	63	<b>890.020.040</b>	3510785412259

EXPERT



**890.020**  
**• HSK 63F BEVESTIGINGSSYSTEEM**

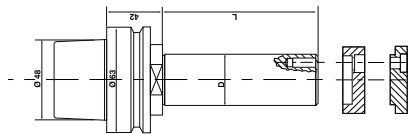

Type	Arbre Ø x L	Rotation	REF	
Snijders houders	Ø 30 x 50	droite/gauche	<b>890.020.050</b>	3510785432875
Snijders houders	Ø 30 x 103	droite/gauche	<b>890.020.123</b>	3510785412280

EXPERT



**890.023**  
**SUPPORT DE MONTAGE ET DÉMONTAGE**

Type	REF	
HSK 63F	<b>890.023.063</b>	3510785412358

EXPERT



**890.032**  
KLEM VOOR C.N.C.-FROUTERKLEMMEN

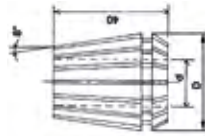

Type	D	d		Tolérance	REF	
ER32	33	6	40	0,5	<b>890.032.006</b>	3510785412525
ER32	33	8	40	0,5	<b>890.032.008</b>	3510785412549
ER32	33	10	40	0,5	<b>890.032.010</b>	3510785412563
ER32	33	12	40	0,5	<b>890.032.012</b>	3510785412570
ER32	33	14	40	0,5	<b>890.032.014</b>	3510785412594
ER32	33	16	40	0,5	<b>890.032.016</b>	3510785412617
ER32	33	18	40	0,7	<b>890.032.018</b>	3510785412624
ER32	33	20	40	0,7	<b>890.032.020</b>	3510785412648

EXPERT



**890.040**  
KLEM VOOR C.N.C.-FROUTERKLEMMEN

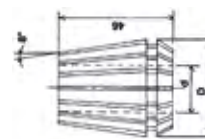

Type	D	d		Tolérance	REF	
ER40	41	6	46	0,7	<b>890.040.006</b>	3510785412686
ER40	41	8	46	0,7	<b>890.040.008</b>	3510785412693
ER40	41	10	46	0,7	<b>890.040.010</b>	3510785412716
ER40	41	12	46	0,7	<b>890.040.012</b>	3510785412730
ER40	41	14	46	0,7	<b>890.040.014</b>	3510785412747
ER40	41	16	46	0,7	<b>890.040.016</b>	3510785412754
ER40	41	18	46	0,7	<b>890.040.018</b>	3510785412761
ER40	41	20	46	0,7	<b>890.040.020</b>	3510785412778
ER40	41	25	46	0,7	<b>890.040.025</b>	3510785412785







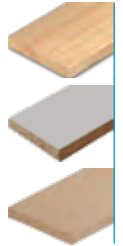

EXPERT

PCD  
DDIAMANTBIT VOOR GROEVEN EN FREZEN

Z = 1+1



PCD

					REF	
10	25	75	12x45	3+1 HM	<b>102512.00</b>	3510785409600
12	34	85	12x45	4+1 HM	<b>123512.00</b>	3510785409624
16	34	94	16x50	4+1 HM	<b>163516.00</b>	3510785409655
16	43	103	16x50	5+1 HM	<b>164316.00</b>	3510785409662
18	43	103	20x50	5+1 HM	<b>184320.00</b>	3510785409693
20	43	103	20x50	5+1 HM	<b>204320.00</b>	3510785409730
20	52	112	20x50	6+1 HM	<b>205220.00</b>	3510785409747

CLASSIC



### TSB.870.CMAN.08

#### SET VOOR DRAAIBOORKOP MET SCHROEFDRAAD M33 X 3,5 MM

- 1 klauwplaat: 1,8 kg, body-Ø 96 mm, spanbereik 67 tot 32 mm, uitschuifbereik 45 tot 82 mm, met BTR-sleutel.
- 1 lapidair ring Ø ext. 75 mm, Ø int. 46 mm.
- 2 pigtails.
- 1 adapterring M33 x 3,5 / 1"x8 TPI + sleutels.



HOUT

REF



870.COFFRETMAN.08

3510785433995

CLASSIC



### TSB.870.MAN

#### UNIVERSELE BOORKOP MET 4 BEKKEN VOOR HOUTDRAAIMACHINE

- Boorkop met concentrische klem schroefdraad M33 x 3,5.
- Geleverd met bekken 50 mm: voor werkzaamheden van 33 tot 65 mm binnenin en 47 tot 80 mm buitenom.
- Varkensstaart
- Afstellen van openen en sluiten door het ronddraaien van de achterste ring (beweging)



HOUT

REF



870.MAN.01

3510785416653

CLASSIC



### TSB.870.CMAN.02

#### DOOS BOORKOP + BOOR Ø 35

- 1 scharnierboor Ø 35 Lt.100 mm.
- 1 verstelbare boorkop, met snelle aanspanning M33 x 3,5 mm.
- Behuizing Ø45 mm / Uitbreiding van 34 tot 42 mm.



HOUT

REF



870.COFFRETMAN.02

3510785434015

CLASSIC

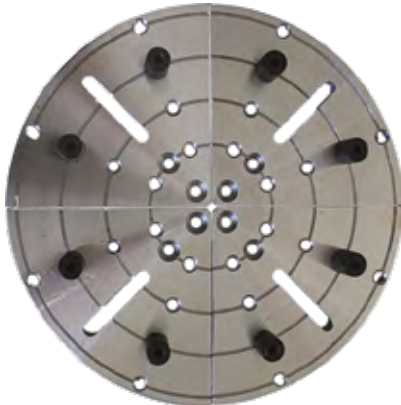

**TSB.870.PLA**  
**KLEMPATEAU Ø190 (4 BEKKEN + ACCESSOIRES)**

- Herstellen van afgewerkte delen.
- 16 PVC-wiggen voor het behoud van het onderdeel: 8 x 17 mm en 8 x 12 mm.
- Capaciteit samengedrukt: 46 - 190 mm.
- Capaciteit uitgezet: 66 - 220 mm.
- Compatibel met boorkop M33 van de 870.COFFRETMAN.08.



HOUT

REF



870.PLATEAU.01

3510785434039

CLASSIC



HM

**TSB.G870.04**  
**DRAAIGEREEDSCHAP 4 IN 1**

- 4 verwisselbare koppen: recht, kegel, holvormige groeven, V-vormige groeven.
- Handvat 300 mm, voor een totale lengte van maximaal 470 mm.



HOUT

REF



870.700.04

3661589092854

CLASSIC



HSS

**TSB.G870.05**  
**DOOS MET 5 DRAAIWERKTUIGEN**

- Guts voor afruwen, profileren, beitelen, V-vormige sleuven, uithollen.



HOUT

REF



870.500.05

3510788705006

CLASSIC



**TSB.G870.03**

**DOOS MET 3 DRAAIWERKTUIGEN**

- Flat plane gouge, diamond chisel, profiling gouge.
- Basics in 195 mm short sleeve, giving a total length of 280 mm.



HOUT

REF



870.500.03

3661589092847

HSS

CLASSIC

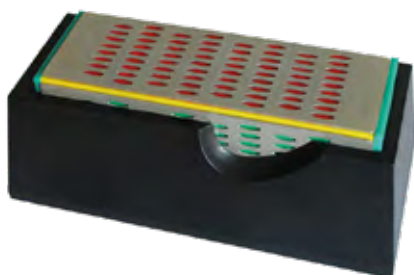

**TSB.785.04**

**SLIJPBLOKGEDIAMANTEERD 4-ZIJDIG**

- Voor houtbeitels, profielmessen, schaafmessen en gereedschap van staal of carbide.
- Afmetingen: 150 x 50 x 50 mm.
- Korrels : 200 + 300 + 400 + 600.

REF



785.000.04

3661589088840

CLASSIC



**TSB.C780.06**

**DOOS MET 6 HOUTBEITELS MET BIMATERIAAL HANDVAT**

- Krachtige prestaties.
- Handvat gecoat met soepel urethaan en metalen versterking aan het uiteinde.
- Breedtes 6, 10, 16, 20, 24, 30 mm.



HOUT

REF



780.500.06

3510787805066

**CLASSIC**

**SER.07301**  
**LICHTE SNELSPANKLEM**

- Klem en steljzer van stevig plastic.
- Rail afm. 20X5 mm van gegalvaniseerd staal, gekarteld.

			REF		
90	20 x 5	150	<b>7301.205.015</b>	1	3661589086808
90	20 x 5	300	<b>7301.205.030</b>	1	3661589086815

**CLASSIC**

**ACC.LUBRI**  
**SMEERSPRAY PROFESSIONELE KWALITEIT 500 ML**

- Verbeterd het glijden van het hout.
- Zonder siliconen, laat geen sporen achter en maakt elke vorm van afwerking mogelijk.
- 650 ml / 500 ml.
- Gevaarlijk product, neem de voorzorgsmaatregelen voor gebruik in acht.

REF		
<b>LUBRISPRAY</b>	12	3510785419029

**CLASSIC**

**ACC.NET125**  
**REINIGER VOOR SNIJGEREEDSCHAPPEN 125 ML**

- Blades, router drill bits, blades, inserts, etc.
- Dilute in 5 times its volume of water.
- Dip the tool in and leave the product to work for a few minutes. Next, brush with a synthetic fibre brush.
- Do not use on lightweight alloy (aluminium) tools. In this case, remove the cutting edges for cleaning.

REF		
<b>NET125</b>	18	3661589041081





CLASSIC



**LSR.LIEGE.RL**  
**AGGLOMERATED CORK**



- Agglomerated cork for lining wood bandsaw wheels.
- Non-canvas tape, to be glued to the steering wheels, sold in rolls of 18 metres.
- Reduces noise impact.
- Absorbs blade tension variations during sawing.
- Glued with neoprene-type double glue.

			REF	
18 m	30	5	<b>LIEGE.RL.30</b>	3661589116673
18 m	35	5	<b>LIEGE.RL.35</b>	3661589116680
18 m	40	5	<b>LIEGE.RL.40</b>	3661589116697
18 m	45	5	<b>LIEGE.RL.45</b>	3661589116703
18 m	50	5	<b>LIEGE.RL.50</b>	3661589116710
18 m	60	5	<b>LIEGE.RL.60</b>	3661589116727



The logo features the word "LEMAN" in a bold, white, sans-serif font. The letters are centered over a red circular graphic that has a jagged, splatter-like edge, resembling a wood chip or a paint splatter. The background of the entire page is a close-up, warm-toned photograph of wood grain, with a dark, textured silhouette of a tree trunk or branch in the lower half.

 @leman-tools

 Leman SAS

 @lemanofficial

 lemanvideo

